

REV 更改号	DATE 日期	REVISION DETAILS 更改内容	APPD 审核并批准
①	2014.08.29	原 $\phi 12.29 \pm 0.08$ 更改为 $\phi 12.5 \pm 0.1$	
		Dia.12.29 +0.08/-0.08 changed to 12.5 +0.1/-0.1	

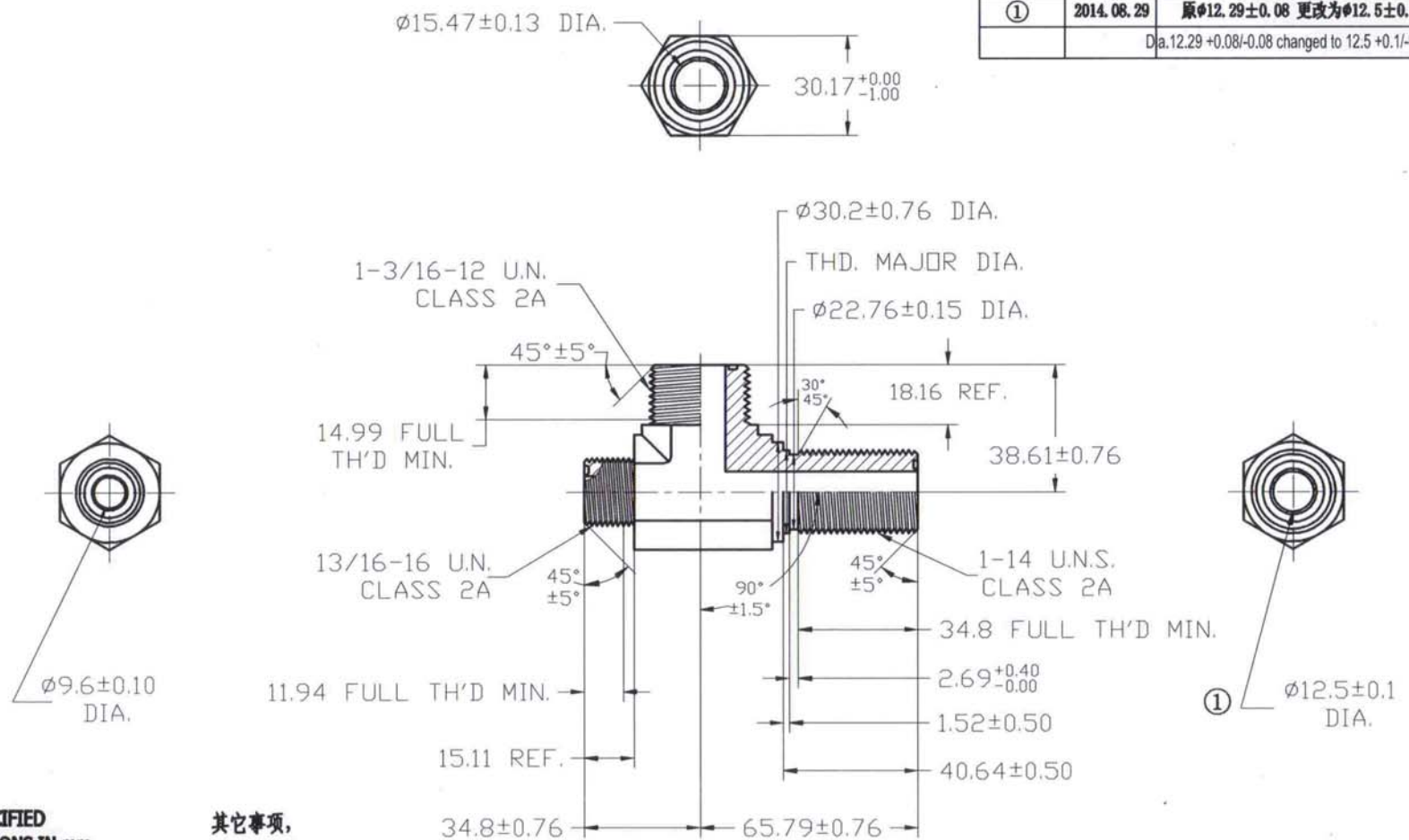

UNLESS SPECIFIED  
ALL DIMENSIONS IN mm  
MACHINED SURFACES  $R_a=3.2\mu m$   
ANGLE TOLERANCES  $\pm 1^\circ$   
Other tolerance except angles,  
in accordance with  
GB/T1804-2000(ISO2768-1)-m  
and GB/T1184-1996(ISO2768-2)-m

其它事项,  
图示尺寸单位为mm  
未注机加工表面粗糙度  $R_a=3.2\mu m$   
角度公差  $\pm 1^\circ$   
其它未注公差 (除角度外) 均按:  
GB/T1804-2000 (ISO2768-1)-m 和  
GB/T1184-1996 (ISO2768-2)-m

PART No 零件名		FS2704-08-10-12	
SCALE:	APPD: 批准 Zhangjian	DRN: 制图 TangHailing	2014.08.30
NTS	DATE: 日期 01/09/14	CHK: 审核 LIJunBiao	2014.08.30

MATERIAL	Chinese steel 45		
FINISH	Remove all sharp edges, burrs, slivers and swarf, break all edges 0.127-0.254mm ZINC PLATED WITH TRIVALENT CHROMATE AND NO RED CORROSION IN 96 HOURS SALT SPRAY TEST. 镀锌, 三价铬钝化, 银白色, 96小时盐雾试验无红斑。		